

EDH AND EDHS SERIES ELECTRIC DUCT HEATERS

DCA (EDH and EDHS series) electric duct heaters are engineered to provide additional room heating for all DCA dehumidification systems. These heaters provide an economical means to provide supplemental room heating.

The duct heater shown on the right is for direct mounting only and not downstream applications. Slip-in (EDHS) duct heater applications are available. They are shipped unattached for on-site installation. A single high voltage power source, separate from the dehumidifier connection, and a low voltage connection are all that is required - allowing for an easy installation.

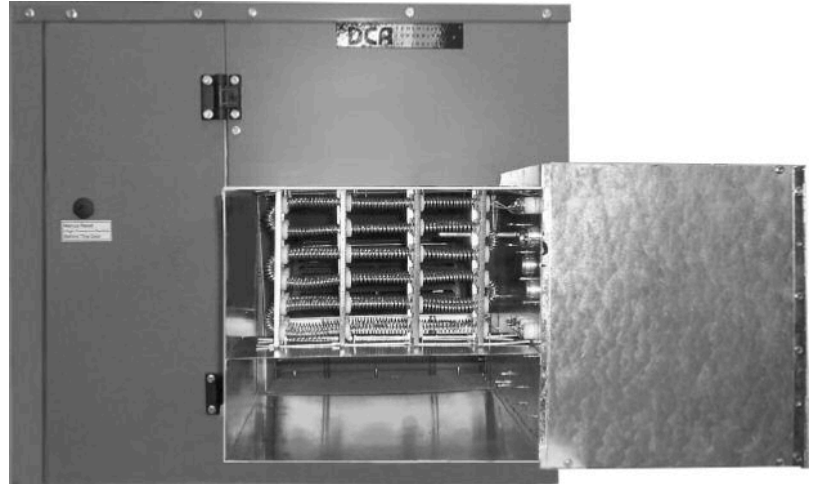

Every heater is shipped complete with air flow pressure switches, high limit controls and fuse blocks. The optional two-stage thermostat ties in with the 24-volt circuitry of any DCA dehumidifier. DCA also offers a

complete line of gas fired in-line duct furnaces where these units may be desired.

All DCA electric duct heaters carry a one-year parts warranty.

STANDARD DCA FEATURES

- **MAGNETIC CONTACTORS**
- **AUTOMATIC HIGH LIMIT SWITCH**
- **AIRFLOW PRESSURE SWITCH**
- **24V TRANSFORMER**
- **PILOT RELAY**
- **STAGING AS REQUIRED FOR EACH 48 AMP CIRCUIT**
- **TIME DELAY BETWEEN STAGES**
- **SINGLE POINT POWER CONNECTION TO TERMINAL BLOCK**
- **LOW VOLTAGE TERMINAL STRIP**
- **GROUNDING LUG**
- **WELDING CONSTRUCTION USING 20 MSG GALVANIZED STEEL**
- **HINGED COVER**
- **WIRING DIAGRAM**
- **FUSED CIRCUITS PER N.E.C., U.L. AND CSA**
- **U.L. LISTED (BUILT TO CONFORM TO N.E.C. REQUIREMENTS)**
- **STRAIGHT FLANGE TO FIT UNIT DISCHARGE**
- **GRADE AA CHROMEL CORROSION-RESISTANT ELEMENT***
- **SLIP IN DUCT HEATERS AVAILABLE**
- **DOWNFLOW DUCT HEATERS AVAILABLE (IN EDHS ONLY)**

* For use with corrosive environments such as indoor swimming pool enclosures, chemical plants and water/wastewater treatment facilities.

**BLOWER MOUNTED HEATERS FOR HORIZONTAL AND UPFLOW APPLICATIONS ONLY
(CONSULT FACTORY FOR DOWNFLOW APPLICATIONS)**

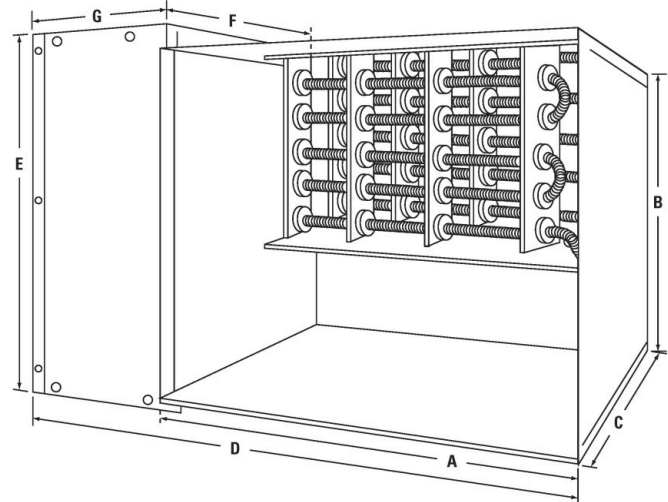

DEHUMIDIFIER MODEL #	DUCT HEATER MODEL	ADD ON ELECTRIC HEAT CAPACITY		BLOWER OUTLET CONNECTION WxH (inches)	SUPPLY VOLTAGE	PHASE	DIMENSIONS IN INCHES						
		KW	BTUH				A	B	C	D	E	F	G
DCA 650Y ¹	EDH0650	4	13,656	9.25" x 10.25"	230	1	9.25"	10.5"	15"	21.25"	12.5"	13"	12"
DCA 900Y	EDH0900	7	23,898	13.25" x 11.375"	230	1	13.5"	11.5"	15"	25.5"	13.5"	13"	12"
					208	3	13.5"	11.5"	15"	25.5"	13.5"	13"	12"
					460	3	13.5"	11.5"	18"	25.5"	13.5"	16"	12"
DCA 1500Y	EDH1500	13	44,382	13.25" x 11.375"	230	1	13.5"	11.5"	17"	25.5"	13.5"	15"	12"
					208	3	13.5"	11.5"	18"	25.5"	13.5"	16"	12"
					460	3	13.5"	11.5"	18"	25.5"	13.5"	16"	12"
DCA 2000Y	EDH2000	15	51,210	15.625" x 13.5"	230	1	15.75"	13.75"	18"	27.75"	15.75"	16"	12"
					208	3	15.75"	13.75"	15"	27.75"	15.75"	13"	12"
					460	3	15.75"	13.75"	18"	27.75"	15.75"	16"	12"
DCA 2500Y	EDH2500	20	68,280	15.625" x 13.5"	230	1	15.75"	13.75"	17"	27.75"	15.75"	15"	12"
					208	3	15.75"	13.75"	18"	27.75"	15.75"	16"	12"
					460	3	15.75"	13.75"	18"	27.75"	15.75"	16"	12"
DCA 3000Y	EDH3000	30	102,420	18.625" x 16"	208	3	18.75"	16.25"	22"	30.75"	18.25"	20"	12"
					460	3	18.75"	16.25"	22"	30.75"	18.25"	20"	12"
DCA 3300Y	EDH3300	30	102,420	18.625" x 16"	208	3	18.75"	16.25"	22"	30.75"	18.25"	20"	12"
					460	3	18.75"	16.25"	22"	30.75"	18.25"	20"	12"
DCA 3600Y	EDH3600	30	102,420	18.625" x 16"	208	3	18.75"	16.25"	22"	30.75"	18.25"	20"	12"
					460	3	18.75"	16.25"	22"	30.75"	18.25"	20"	12"
DCA 4100Y	EDH4100	35	119,455	18.625" x 16"	208	3	18.75"	16.25"	32"	30.75"	18.25"	30"	12"
					460	3	18.75"	16.25"	22"	30.75"	18.25"	20"	12"
DCA 4800Y	EDH4800	35	119,455	18.625" x 16"	208	3	18.75"	16.25"	32"	30.75"	18.25"	30"	12"
					460	3	18.75"	16.25"	22"	30.75"	18.25"	20"	12"
DCA 5500Y	EDH5500	35	119,455	18.625" x 16"	208	3	18.75"	16.25"	32"	30.75"	18.25"	30"	12"
					460	3	18.75"	16.25"	22"	30.75"	18.25"	20"	12"

Above specifications for all DCA 454B series Air-Cooled Non Water Heating and Water Heating Assist Dehumidifiers, unless otherwise specified by the notes below.

Control voltage for above 24V. Above duct heaters can be ordered with less kW than listed, for each model if needed.

¹ Single phase models only

SLIP-IN HEATERS

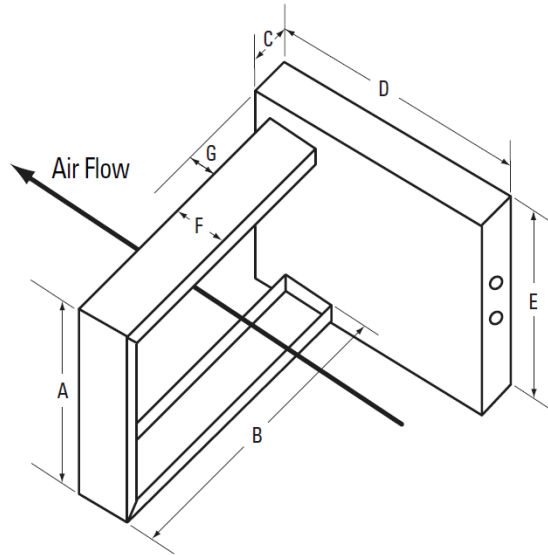

DEHUMIDIFIER MODEL #	DUCT HEATER MODEL	ADD ON ELECTRIC HEAT CAPACITY		DUCT DIMENSIONS WxH (inches)	SUPPLY VOLTAGE	PHASE	MAX DIMENSIONS IN INCHES						
		KW	BTUH				A	B	C	D	E	F	G
DCA 650Y ¹	EDHS0650	4	13,656	7" x 12"	230	1	9.75"	5.75"	5"	24"	12"	7"	4"
DCA 900Y	EDHS0900	7	23,898	14" x 11"	230	1	9.75"	12.75"	5"	24"	12"	7"	4"
					208	3	9.75"	12.75"	5"	27"	12"	7"	4"
					460	3	9.75"	12.75"	5"	27"	12"	7"	4"
DCA 1500Y	EDHS1500	13	44,382	14" x 14"	230	1	11.75"	12.75"	5"	33"	14"	7"	4"
					208	3	11.75"	12.75"	5"	30"	14"	7"	4"
					460	3	11.75"	12.75"	5"	24"	14"	7"	4"
DCA 2000Y	EDHS2000	15	51,210	21.5" x 15"	230	1	12.75"	20.75"	5"	39"	15"	7"	4"
					208	3	12.75"	20.75"	5"	30"	15"	7"	4"
					460	3	12.75"	20.75"	5"	24"	15"	7"	4"
DCA 2500Y	EDHS2500	20	68,280	21" x 16"	230	1	13.75"	19.75"	5"	39"	16"	7"	4"
					208	3	13.75"	19.75"	5"	33"	16"	7"	4"
					460	3	13.75"	19.75"	5"	24"	16"	7"	4"
DCA 3000Y	EDHS3000	30	102,420	22" x 18"	208	3	15.75"	20.75"	5"	36"	18"	7"	4"
					460	3	15.75"	20.75"	5"	27"	18"	7"	4"
					460	3	15.75"	23.75"	5"	36"	18"	7"	4"
DCA 3300Y	EDHS3300	30	102,420	25" x 18"	208	3	15.75"	23.75"	5"	36"	18"	7"	4"
					460	3	15.75"	23.75"	5"	27"	18"	7"	4"
					460	3	15.75"	23.75"	5"	27"	18"	7"	4"
DCA 3600Y	EDHS3600	30	102,420	25" x 18"	208	3	15.75"	23.75"	5"	36"	18"	7"	4"
					460	3	15.75"	23.75"	5"	27"	18"	7"	4"
					460	3	15.75"	22.75"	5"	69"	18"	7"	4"
DCA 4100Y	EDHS4100	40	136,560	24" x 18"	208	3	15.75"	22.75"	5"	69"	18"	7"	4"
					460	3	15.75"	22.75"	5"	33"	18"	7"	4"
					460	3	16.75"	26.75"	7"	60"	19"	7"	4"
DCA 4800Y	EDHS4800	40	136,560	28" x 19"	208	3	16.75"	26.75"	5"	30"	19"	7"	4"
					460	3	16.75"	26.75"	5"	30"	19"	7"	4"
					460	3	19.75"	27.75"	7"	57"	22"	7"	4"
DCA 5500Y	EDHS5500	50	170,700	29" x 22"	208	3	19.75"	27.75"	5"	33"	22"	7"	4"
					460	3	19.75"	27.75"	5"	33"	22"	7"	4"

Above specifications for all DCA 454B series Air-Cooled Non Water Heating and Water Heating Assist Dehumidifiers, unless otherwise specified by the notes below.

Control voltage for above 24V. Above duct heaters can be ordered with less kW than listed, for each model if needed.

¹ Single phase models only

SLIP-IN HEATERS (CONTINUED)

DEHUMIDIFIER MODEL #	DUCT HEATER MODEL	ADD ON ELECTRIC HEAT CAPACITY		DUCT DIMENSIONS WxH (Inches)	SUPPLY VOLTAGE	PHASE	DIMENSIONS IN INCHES						
		KW	BTUH				A	B	C	D	E	F	G
DCA 6500Y	EDHS6500	50	170,700	36" x 24"	208	3	21.625"	34.75"	7"	54"	25"	7"	4"
							460	3	21.625"	34.75"	5"	30"	25"
DCA 7000Y	EDHS7000	50	170,700	36" x 24"	208	3	21.625"	34.75"	7"	54"	25"	7"	4"
							460	3	21.625"	34.75"	5"	30"	25"
DCA 8000Y	EDHS8000	65	221,919	40" x 26"	208	3	23.625"	38.75"	7"	63"	26"	7"	4"
							460	3	23.625"	38.75"	5"	30"	26"
DCA 9000Y	EDHS9000	75	256,060	41" x 28"	208	3	25.625"	39.75"	7"	75"	28"	7"	4"
							460	3	25.625"	39.75"	5"	27"	28"
DCA 11000Y	EDHS11000	90	307,272	46" x 30"	208	3	27.625"	44.75"	5.5"	30"	30"	7"	4"
							460	3	27.625"	44.75"	7"	33"	30"
DCA 14000Y	EDHS14000	110	375,555	50" x 34"	208	3	33"	49"	5.5"	34"	34"	7"	4"
							460	3	31.625"	48.75"	7"	39"	35"

CURRENT DRAW, MCA AND MOCP

DEHUMIDIFIER MODEL #	KW	CURRENT DRAW (AMPS)											
		230/1			208/3			230/3			460/3		
		FLA	MCA	MOCP	FLA	MCA	MOCP	FLA	MCA	MOCP	FLA	MCA	MOCP
DCA 650Y ¹	4	17.39	21.74	26.09	NA	NA	NA	NA	NA	NA	NA	NA	NA
DCA 900Y	7	30.43	38.04	45.65	19.43	24.29	29.15	17.57	21.97	26.36	8.79	10.98	13.18
DCA 1500Y	13	56.52	70.65	84.78	36.09	45.11	54.13	32.63	40.79	48.95	16.32	20.40	24.48
DCA 2000Y	15	65.22	81.52	97.83	41.64	52.05	62.46	37.65	47.07	56.48	18.83	23.53	28.24
DCA 2500Y	20	86.96	108.7	130.43	55.52	69.40	83.27	50.21	62.76	75.31	25.10	31.38	37.65
DCA 3000Y	30	NA	NA	NA	83.27	104.29	124.91	75.31	94.14	112.96	37.65	47.07	
DCA 3300Y	30	NA	NA	NA	83.27	104.29	124.91	75.31	94.14	112.96	37.65	47.07	56.48
DCA 3600Y	30	NA	NA	NA	83.27	104.29	124.91	75.31	94.14	112.96	37.65	47.07	
DCA 4100Y	40	NA	NA	NA	111.03	138.79	166.55	100.41	125.51	150.62	50.21	62.76	56.48
DCA 4800Y	40	NA	NA	NA	111.03	138.79	166.55	100.41	125.51	150.62	50.21	62.76	75.31
DCA 5500Y	50	NA	NA	NA	138.79	173.49	208.19	125.51	156.89	188.27	62.76	78.45	56.48
DCA 6500Y	50	NA	NA	NA	138.79	173.49	208.19	125.51	156.89	188.27	62.76	78.45	94.14
DCA 7000Y	50	NA	NA	NA	138.79	173.49	208.19	125.51	156.89	188.27	62.76	78.45	94.14
DCA 8000Y	65	NA	NA	NA	180.43	225.53	270.64	163.17	203.96	244.75	81.58	101.98	122.38
DCA 9000Y	75	NA	NA	NA	208.19	260.23	312.28	188.27	235.34	282.41	94.14	117.67	141.20
DCA 11000Y	90	NA	NA	NA	249.82	312.28	374.73	225.93	282.41	338.89	112.96	141.20	169.44
DCA 14000Y	110	NA	NA	NA	305.34	381.67	458.01	276.13	345.17	414.2	138.07	172.58	207.10

Above specifications for all DCA 454B series Air-Cooled Non Water Heating and Water Heating Assist Dehumidifiers, unless otherwise specified by the notes below.
Control voltage for above 24V. Above duct heaters can be ordered with less kW than listed, for each model if needed.

¹ Single phase models only